

medlab

One Channel ECG OEM Module

EG 01000

Technical Manual

Copyright © Medlab 2008
Version 2.1
31.05.2008

Revision:

2.0	Completely revised the document	03.10.2007
2.1	Corrected error in S command description	31.05.2008
	Corrected wave samples numerical range	

Copyright Medlab 2008

All rights reserved

Medlab does not assume any responsibility for use of the product described, no patent licenses are implied and Medlab reserves the right at any time without notice to change said product and specifications.

For the most current product information visit us at www.medlab.eu.

Contents

Mechanical Dimensions, Overview	4
Scaling and Physical Units	5
Specifications	6
Connector Assignment	7
Serial Transmission	8
Software Protocol	9
PC Test Program	10
Filter Adjustment	11
Regulatory Considerations	12

Mechanical dimensions of the module

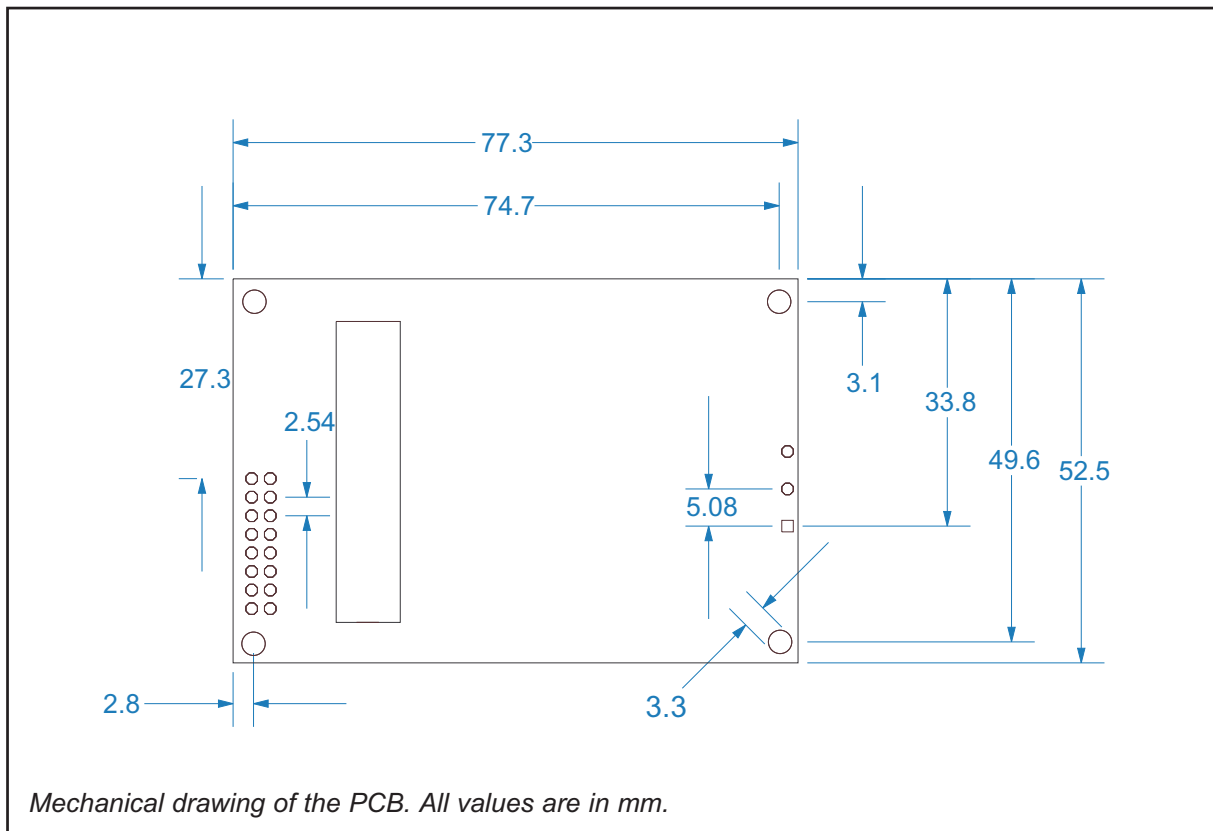

Overview

The scope of this document is the description and specification of Medlab's ECG board EG1000. It will help anybody who is familiar with programming and medical electronics to integrate the board into his own electronic system.

The EG1000 measures one channel of a patient's ECG over a three lead cable. What is actually measured is the differential input voltage between the red and yellow input clamps of the cable. These leads carry the differential voltage to the input stage of the amplifier, the third lead, normally coloured in green, is the isolated ground of the module. It should not be connected to the mains ground of the medical system (neither protective nor functional earth). The EG1000 has a fully IEC601 compliant isolation on board, and if properly integrated, can be used to develop a medical device of type CF isolation class. No connections except to the patient cable shall be made on the input side of the module (see drawing on the next page).

Possible applications include:

Basic ECG monitoring, triggering of CT systems, triggering of ultrasound systems, triggering of lithotripters, ECG recording in labs or university classes aso.

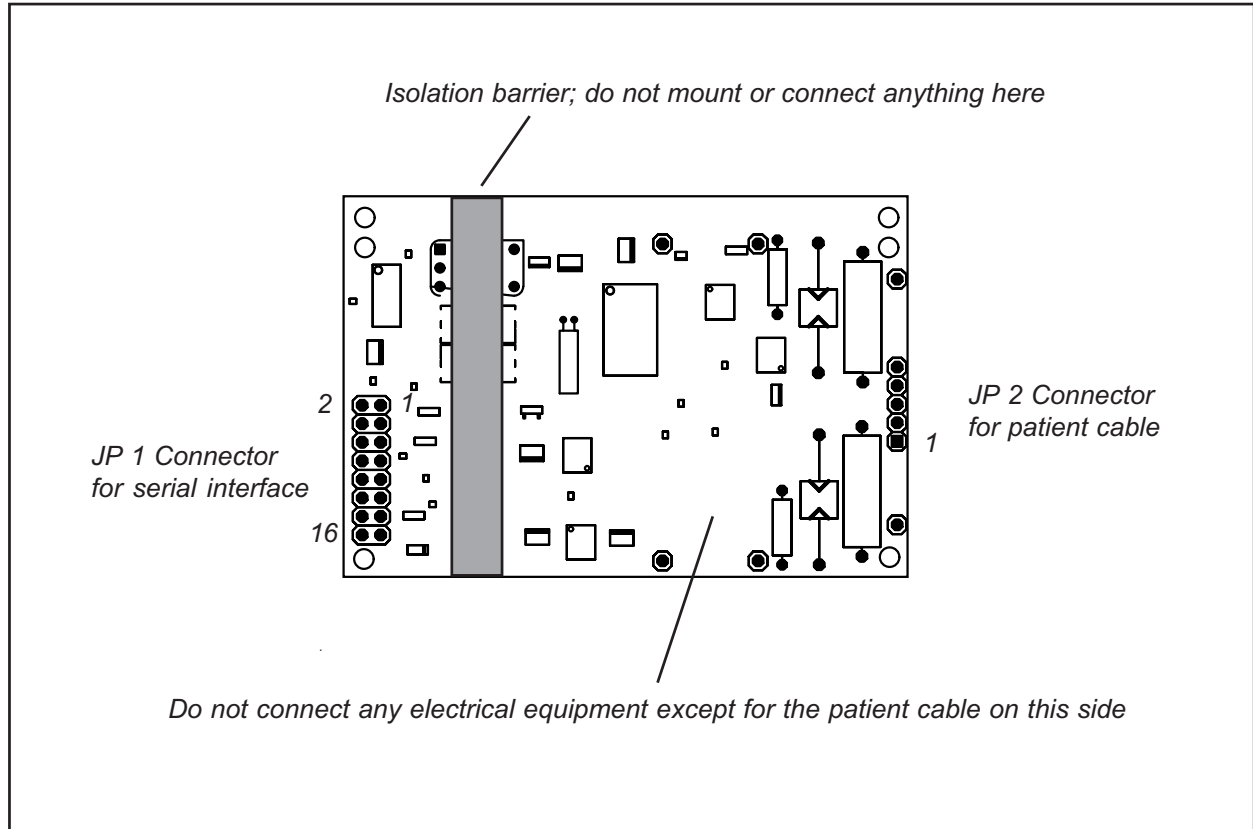

Scaling and Physical Units

Scaling of ECG curves is traditionally done in the physical unit "cm/mV" for the y-axis and "mm/sec" for the x-axis. This remains from times when the amplified signal was written directly on paper using strip recorders.

Since it is not defined what kind of display is interfaced by the user to the EG01000, we use in this description the direct AD converter values (0 to 255) for the y-axis and the numbers of sample points sent per second for the x-axis (s^{-1} , Hz).

For the medium amplification stage (A1), the zero line of the ECG is at the middle of the AD range (0x80 or 128). 1mV is equal to 100 steps, e.g. "228" received as a sample value would be equal to 1 mV in the positive direction, "28" would be equal to 1mV in the negative direction. For the high amplification stage (A2), this resolution is doubled, e.g. 228 relates to 0.5mV. For the low amplification stage (A0), the resolution is half, e.g. 228 relates to 2mV.

Traditional resolutions for the time axis are 12.5mm/sec, 25mm/sec and 50mm/sec. The three most commonly used ranges for the amplification are 2cm/mV, 1 cm/mV and 0.5cm/mV.

Technical data (Specifications)

Mechanical data:	See page 4, board drawing. 77x52.5 PCB, max. thickness 10 mm
Attachment:	Four M3 screws. Nylon screws are recommended
Weight :	28 g
Operating voltage:	5 Volt, +- 10%
Power consumption:	26..30 mA (150mW) while measuring
Input:	Defibrillation protected
Isolation:	4000Volts RMS
Patient Isolation:	CF
Amplification:	Three levels, user selectable
Data transmission:	Three trasmission speeds, 50/100/300 Hertz
Filtering:	50 Hz and 60 Hz notch filter included
Maximum DC offset:	300mV
Amplifier frequency range:	0.3 to 30 Hz.
Pulse detection:	30 .. 250 bpm +- 1%, +- 1 Digit, 8 beat averaging
Protocol:	Bidirectional serial protocol at 9600 Baud (8,N,1)
Connector:	16 pin interface connector, 2 rows of 8 pins, 2.54mm

Connectors

(see drawing on page 4 for location)

Header for host connection:

JP1:	1	Ground
	2	Ground
	3	Txd (TTL level)
	4	Txd (RS232 level +- 5 Volt)
	5	Rxd (TTL level)
	6	RxD(RS232 level +- 5 Volt)
	7	Not connected
	8	Not connected
	9	Not connected
	10	Not connected
	11	Not connected
	12	Not connected
	13	Shutdown, VCC level here powers down whole board
	14	Not connected
	15	VCC input
	16	VCC input

Header for patient cable connection

JP 2:	1	Positive input
	2	Not used
	3	Patient ground
	4	Not used
	5	Negative input

Three Lead Patient Cable

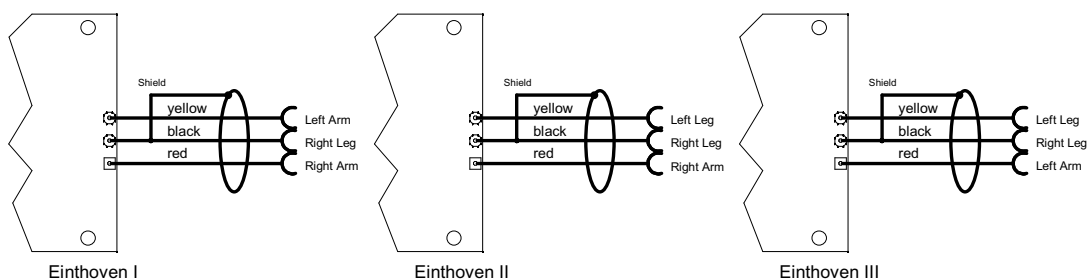

Serial Transmission

The module connection is done by serial, asynchronous communication at 9600 baud, 8 data bits, one stop bit, no parity bit. Both CMOS (0..5 volts) and RS232 (+/- 5 volts) voltage levels are available.

The RS232 levels are helpful during evaluation of the board. This can be done using any PC and a special software. It is recommended to do the connection in the final system using the CMOS levels, since this saves parts and energy on the host side of the data stream, no level translators are needed on the host side.

The EG01000 sends a continuous data stream and receives commands. Commands are one byte characters, some of them have one byte as additional parameter, others are executed after the ECG board receives the command byte alone.

There is a command that changes the number of ECG trace sample values sent per second ("S", like "speed"). This command takes one byte between "0" (ASCII 0x30) and "2" (ASCII 0x32) as parameter.

Command "A", like "amplification" also requires one parameter between "0" and "2" to switch the amplification of the ECG amplifier of the module.

Command "M", like "mode" brings the module into an internal simulation mode, where no real samples, but a previously stored waveform is transmitted to the host. Sending "N" like "normal" returns the module to the normal state. This is extremely helpful during integration of the board into the host system.

Command "C", like "calibration", switches the trace to a 1mV reference curve for about 1 second. After that, the module returns to send ECG sample values.

Command "5" and "6" change the internal notch filter of the module to 50 or 60 Hz.

The module powers up with amplification and speed set to level 0, which means lowest amplification stage and transmission of 300 sample points per second. Simulation mode is off at power up, the notch filter is set to 50 Hz.

The neutral line of the ECG always lies at 128, the module transmits unsigned byte data. While a lead off condition is active, a pulse value of 0 and a neutral line of 128 is transmitted.

Serial Transmission Protocol

All data is transmitted at 9600 baud, 8 bits, 1 stop bit, no parity. Each time a pulse is detected by the board's internal algorithm, a block with a new, averaged pulse rate is transmitted. The pulse detector is of high quality, and the point in time where the pulse marker (0xFA) is transmitted can be used for triggering applications that require to synchronize other devices to a patient's R-wave.

The ECG wave sample points are transmitted continuously with 50,100 or 300 bytes per second, according to the user's last command. The curve sample points lie between 0 and 246.

Values that are higher than 246 (0xF6) are used for marking the following byte as a new data values according to the following definition:

Marker byte	Meaning of following byte(s)	Commands accepted by the module
0xF8	wave sample points follow	"M" switch to simulation mode "N" switch back to normal mode "S" "0" send ECG trace with 300 Hz "S" "1" send ECG trace with 100 Hz "S" "2" send ECG trace with 50 Hz
0xFA	Pulse value follows	"A" "0" amplification stage 0 "A" "1" amplification stage 1 "A" "2" amplification stage 2
0xFB	Info byte follows	"5" turn on 50 Hz notch filter "6" turn on 60 Hz notch filter
0x11	The only info byte defined is 0x11, "LEAD OFF" Others may be added in the future	"C" calibrate, send 1mV pulse

Definition of data stream sent by the module

Example of a received data stream at the host side:

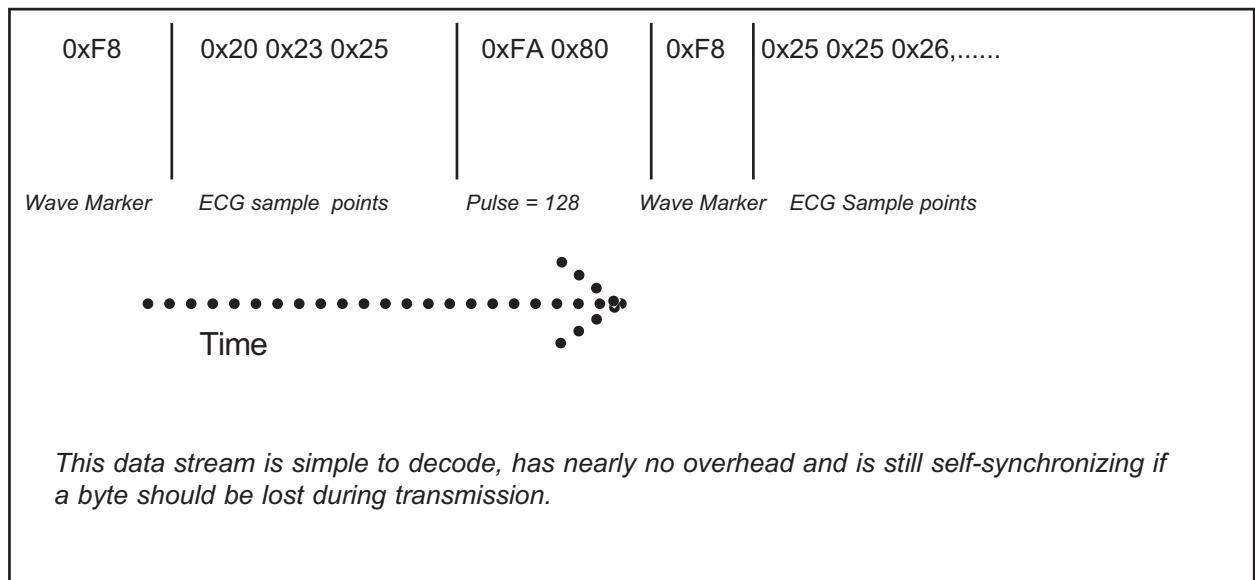

Test Program

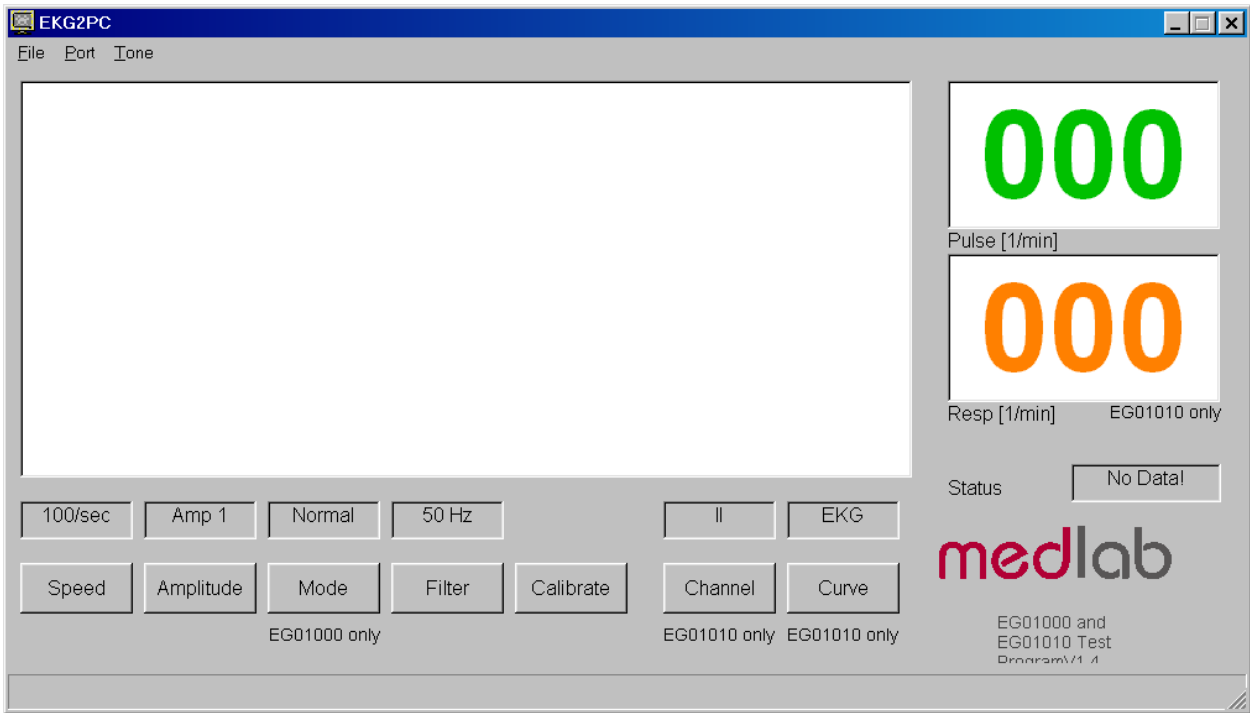

For easy integration of the module into medical systems, a test software has been made available. The EG01000 can be connected directly to a PC, the received data is shown on the screen.

To run the program, connect the EG01000 board to the serial port of a PC. If the PC has no serial port, please use a USB to RS232 adapter and install the driver of this adapter first. Connect the power input to a 5 volts DC source. Then start the program on your PC and select the serial port number in the "Port" menu.

Commands can be sent to the board by pressing the command buttons in the application. Since the same software can be used for EG01000 and the three channel EG01010 board, some buttons have no function when used with the EG01000.

The software is available free of charge under: www.medlab.eu, on the page describing the EG01000. The software is written in Visual Basic 6 and the source code is also included in the download package.

Filtering

The bandwidth of the filter for the ECG Signal is always a compromise between signal stability and fidelity in reproduction of the real form of the ECG: the critical part is the highpass filter that eliminates the drift of the trace due to DC voltages building up at the electrodes.

This filter can be adapted on our ECG board by changing R1 or C1 on the board. The -3db frequency of the highpass can be calculated with the formula:

$$f = 1/(2 * \pi * R1 * C1).$$

When the board is delivered, this frequency is adjusted to 0.30 Hz by using 150nF for C1 and 3.3Megohm for R1.

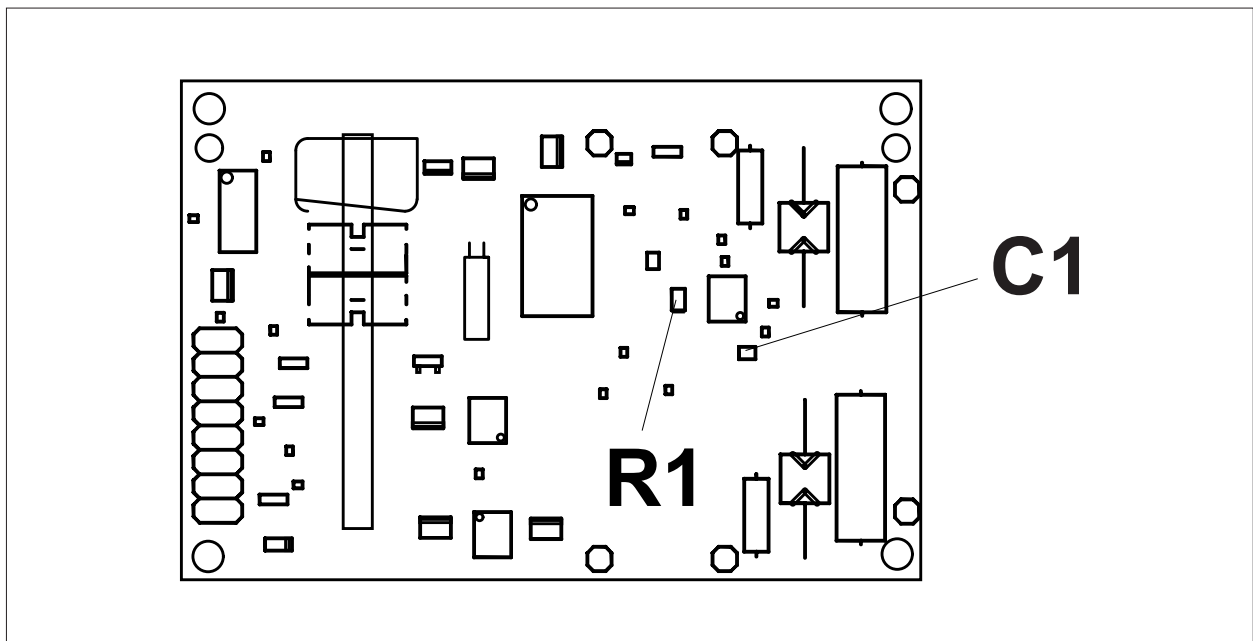

Regulatory considerations

The module described in this document is not a final medical product. That means that it cannot be used as a standalone unit to do measurements on a patient. Therefore, the EG01000 is not CE-marked.

The customer has to undertake the procedure of CE-marking with the final product that he develops using the PCB.

However, due to the large experience, Medlab will be able to support customers during the certification process.

The device is not 510k registered, which is not possible for a module. Only final products that will be sold in the USA have to - and can - undertake the process of 510K approval.

medlab

medizinische Diagnosegeräte GmbH

Erzbergerstraße 115

76133 Karlsruhe

Germany

Tel ++49 (0) 721 62512 0

Fax ++49 (0) 721 62512 12

sales@medlab.eu

www.medlab.eu